

CNC 6-Sided Drilling Machine NCB612

NichoMachines Machinery



Find more: www.nichomachines.com



3-year warranty*
ensuring no hassle
and unforeseen costs



Quick return on
investment



Low Total Cost of
Ownership



Ensuring low price
by sourcing cleverly
in large quantities

Highlights

- Multi-functional CNC drilling machine is able to drill from 6 sides and top&bottom grooving, simple routing meets different process requests and gives batch-size-one production max flexibility;
- Machine is configured with one top and one bottom drilling blocks&3.5kw main spindle.
- Software is open port, support most formats in market.
- Standard with side outfeed conveyor table, selectable to outfeed from front and back.

Details

1. Machine body

- Heavy duty machine body is welded with square tube and laser cut of advanced CNC machine for metal work, hence enhance the stability in the process; Gantry and machine body have been designed as a whole; Machine net weight up to 3200kg-very heavy duty; 2

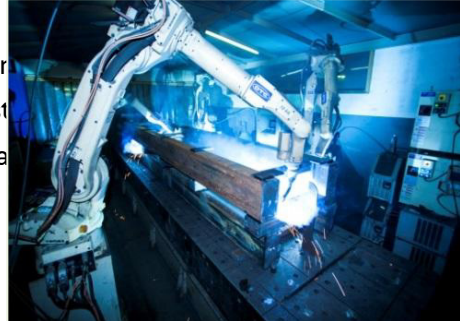

- Frame body pass the heat treatment and vibration aging treatment to guarantees the whole service life without deforming.



- After sandblasting and painting, the top-grade CNC metal processing machines are used to process the body and components to make sure perfect quality and detail.



2. Quality control

- Advanced measuring equipment and strict QC system also help to make sure the final machine we offer to our customers are of high quality;



- All the machines are delivered with Quality Certificate signed by QC specialist.



3. Professional assembly line

- Assembly is final and important step for better machine performance. Nanxing's professional assembly lines from machine body to small electrical components were by experienced technicians that guarantee machine standardization and performance.



4. Long clamp beam & fast clamps

- The design of 5.5m longer high-rigidity clamp beam on two sides ensure stable and fast clamp moving with least vibration, and reduces the frequency of switching clamp during processing, thus higher efficiency.
- The movement of clamps is controlled by servo and along inclined rack&pinion for accuracy in process; Board thickness: 10-60mm
- Air jet to remove the dust on board

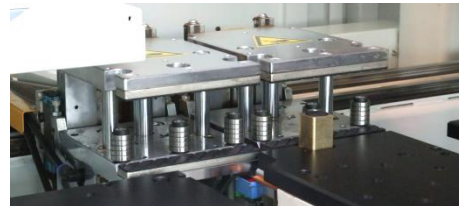
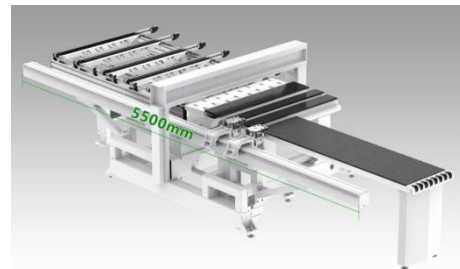

5. Infeed air float table

- Floating feed table in front makes boards smoothly moving on table, avoid scratches on panel surface.
- Standard with air blower



6. Feed-out

- Can choose feed mode feed-in & out in front side or feed-in in front and feed-out in back.
- Feed out in back mode with 2 steps smooth out.
- The hairbrush and conveyor belt can offer very good protection to the surface.

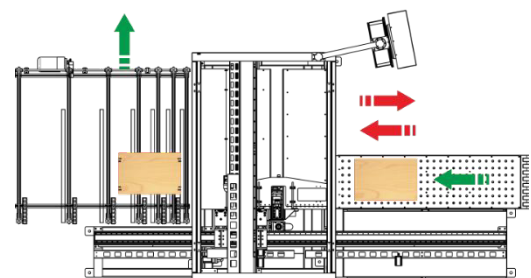

7. Positioning

Side aligner

- Dual clampers cooperate well with auto side alignment to guarantee precision and stability in panel processing.



Stopper

- The stop is strong design to offer stable alignment. Besides, the sensor can measure the workpiece X length. The air blow will clean the dust on the sensor.



Support plates

- Top and bottom drilling blocks and main spindles have support plate to offer the board a support force when the other side is being processed to ensure accuracy in process.



8. Accurate movement of each axis

X, Y, U direction

- Transported by inclined rack and pinion of large bearing capacity and strong stability;

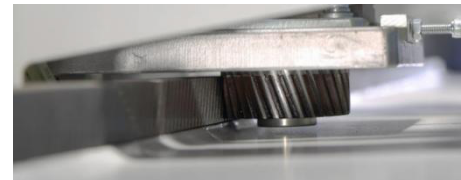

Z direction

- Ball screw rod gives the machine added precision in Z direction.



Servo motor

- The accurate movement of each axis is ensured by the high quality servo motors.
- Max travelling speed: X/U/Y/Z:135/135/75/30m/min



9. Auto grease

- Linear guiding rail and bearings can be greased automatically by electrically controlled greasing pump, save maintaining job.



10. Board length detector

- There would be alarm when lengthwise detector detects length is not correct to ensure operator puts the right board.

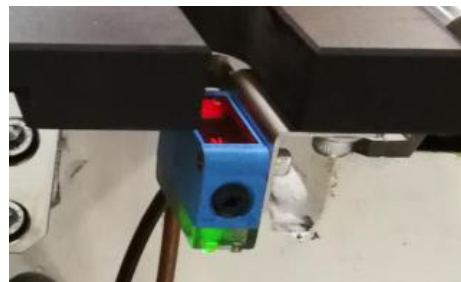

11. Optimized drilling blocks layout

Top drilling block:

- 3.5kw main spindle
- 1 drilling block: Vertical drills: 18; Horizontal drills: 6 in X direction; 4 in Y direction. 5000rpm rotating speed, hole edge is smoother, friendly for hinge hole.

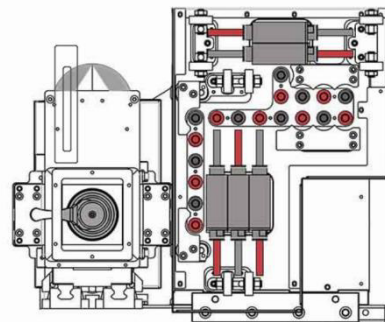

Bottom drilling block:

- 3.5kw main spindle+ one boring block
- 9 vertical drills
- Collinear vertical drills of top and bottom drilling blocks, faster to drill through holes.
- Support plates prevent boards from deforming when processing on top



Optimized spindle dust collecting system

- Optimized main spindle's dust collecting has better collecting performance.



12. Quick change tool

- Machine has a door, tool can be accessed by opening the door.
- Drills rods are quick install head, easy to change.



13. Cable chain

- High-quality cable chain used to drag and protect electric wire and air tube during movement of each axis for longer service life.



14. Min. processing part

- Drilling block design and software can do drilling for narrow parts
- Panel length: 200-3000mm Panel width 30-1200mm



15. Stack processing

- Support stacking processing if hole position is mirror



16. Hand controller

- Hand controller makes commissioning more convenient.



17. Start button & pedal switch

- Starts by Start Button or foot pedal
- Machine featured start pulling bar, easy to start especially for long boards.



18. E-stop & Pause bar

- Machine featured pause bar, safety for operator
- E-stop



19. Light barrier

- A light barrier is put in infeed area, make sure machine won't move when operator stands there for safety.



20. Industrial computer

- Windows 10 operating system.
- IPC computer;



21. Control system

- SYNTEC CNC control system and Operation Software, reliable and the process efficiency is 20%-25% faster



22. Excellent electrical components

- Electrical parts and components are in reliable brand, standard and clean wiring connection make machine reliability and stability.
- Air conditioner on control cabinet to keep electrical components always in proper working condition.



23. Bar-code reader

- Read the panel processing information generated by furniture making software, machine will recall corresponding program to process automatically by scanning the Bar code info.



24. File format support.

- Open port to interface with furniture design software, support the file format: MPR, DXF, BAN, BPP, PDX; XML; XXL.



25. User-friendly operation

- Control interface is modern and friendly,
- Manual programming interface is easy to operate, functions are available at a glance like horizontal hole, vertical hole, grooving, flip, mirror, rotate etc.
- Simulation function
- Easy tools setting;
- Statistics function, production capacity is available at a glance
- Set tool life, software will remind when tool is time to change for smart tool management

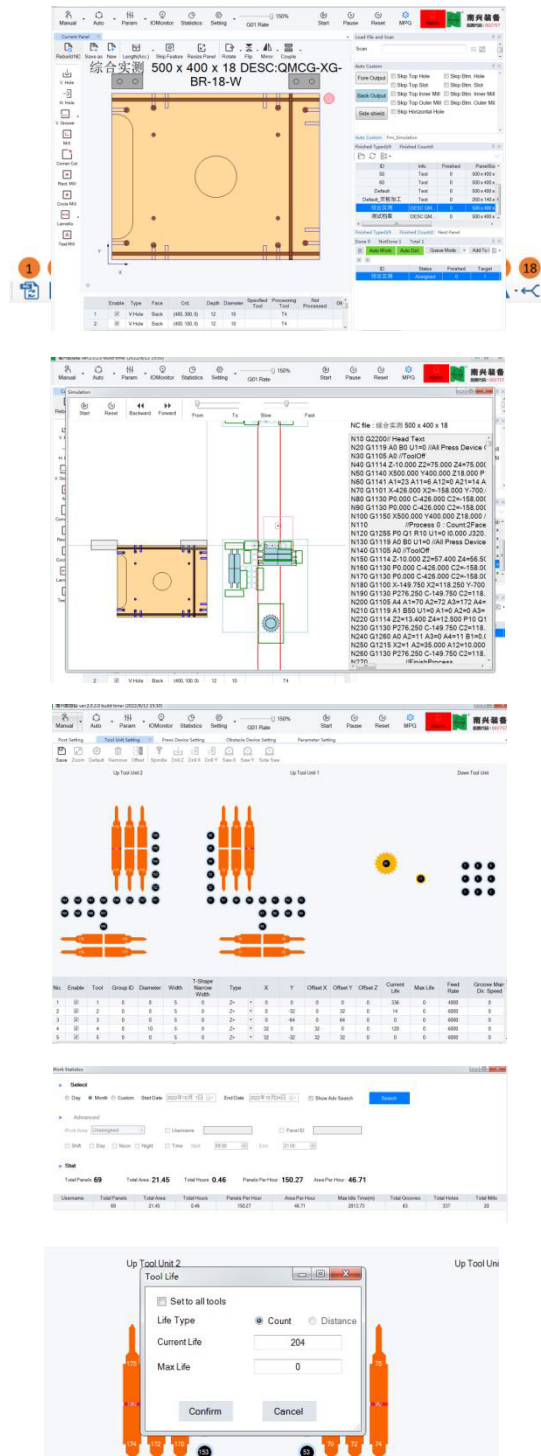

Technical Data

Total power	18.03 KW	
Machine size	6,150 * 2,273 * 2,325 mm	
Power supply	380V/50Hz	
Air supply	0.6-0.7MPa	
Total weight	3,200Kg	
Control system	Brand	SYNTEC
Panel size	Length	200-3,000mm
	Width	30-1,200mm
	Thickness	10-60mm
Max. traveling speed	(X/U) axis	135m/min
	Y axis	75m/min
	Z axis	30m/min
Drilling blocks	Drilling block qty	Top 1; Bottom 1
	Vert. drills qty (top)	18
	Horiz. drills qty (top)	X: 6 + Y: 4
	Vert. drills qty (Bottom)	9
	Max drill diameter	Φ35mm
	Drill spacing	32mm
	Rotation speed	5000rpm
	Shank diameter	Φ10mm
Main spindle	qty	Top 1 bottom 1
	power	3.5kw×2
Dust collector	qty	2
	diameter	Top 200mm×1 Bottom 125mm×1
	speed	≥28m/min

The company continuous to improve the product specifications and design details, the specifications are subject to change without notice. 230606